

ASPHALT RECYCLING

RSS 120-M

SHREDDER, IRON SEPARATOR
AND SCREENER



AMMANN

A 3-IN-1 MACHINE

The Ammann RSS 120-M takes on shredding, separating and screening as if it were custom-built for each task. The machine consistently and efficiently processes recycled asphalt, from milled materials to asphalt slabs and large chunks. Patented technology utilises milling cutters with interchangeable teeth for efficient and gentle crushing. The technology is both powerful and fuel efficient, and it complements other environmental friendly efforts built into the machine, including minimised sound and dust emission levels.



HIGHLIGHTS

- Versatile all-in-one equipment
- Mobile and autonomous with 30 minutes set-up time
- Simple one-man operation
- Reliable performance without interruption
- Protective processing maintains grain sizes of the input recycling material
- Easy maintenance and fast servicing



READY TO WORK IN ALL CONDITIONS

Productivity is where you make your money. The RSS 120-M starts working within 30 minutes of arriving at a jobsite. It remains productive in all weather conditions, with a maximum capacity of 180 tons per hour. When the job is done, the RSS 120-M can be quickly loaded and relocated.

EASY MAINTENANCE

- Fast replacement of wear parts
- Robust, long-life wear protection
- Fast change of screen meshes
- Notification system for intuitive troubleshooting



HIGHLY MOBILE

- Track-mounted for mobility and autonomy
- Standard transport by flatbed truck
- From installation to production in 30 minutes

ALL-IN-ONE SOLUTION

- Primary shredder
- Iron separator
- Screening machine with two screen decks
- Oversize grain recirculator
- Secondary shredder

FEWER FINES

- Smooth and gentle shredder preserves grain sizes of input material
- Processed material allows higher addition of recycling material to asphalt mix

CONTINUOUS FEEDING

- Hydraulic fingers ensure continuous load
- The shredder motor stops when clogging occurs and reverses



PERFORMANCE AND VERSATILITY

- Slowly rotating primary shredder for high output and fewer fines
- Hydraulically adjustable gap in primary shredder



SUSTAINABLE POWER SUPPLY

- Diesel engine with 256 kW
- Power generator with 400 KVA
- Drive motors electrically powered
- High fuel efficiency



SIMPLE ONE-MAN OPERATION

- Control system with easy-access panel
- Remote control for flexible operation



AFTER SALES

Technician training provided by Ammann helps protect your investment, while operator training ensures your team is able to utilise all the features and benefits built into your equipment.

PARTS KITS FOR EFFICIENT MAINTENANCE

Ammann offers parts packages that ensure all maintenance is current, making your equipment efficient and also protecting it from premature wear that can result from poor service practices.

LONGEVITY AND AVAILABILITY

Ammann parts provide the best value over the life of your equipment. The parts are built to last and have a long life. Well attuned logistics processes assure a high availability and short lead times for parts.

DIMENSIONS

WORKING CONDITIONS

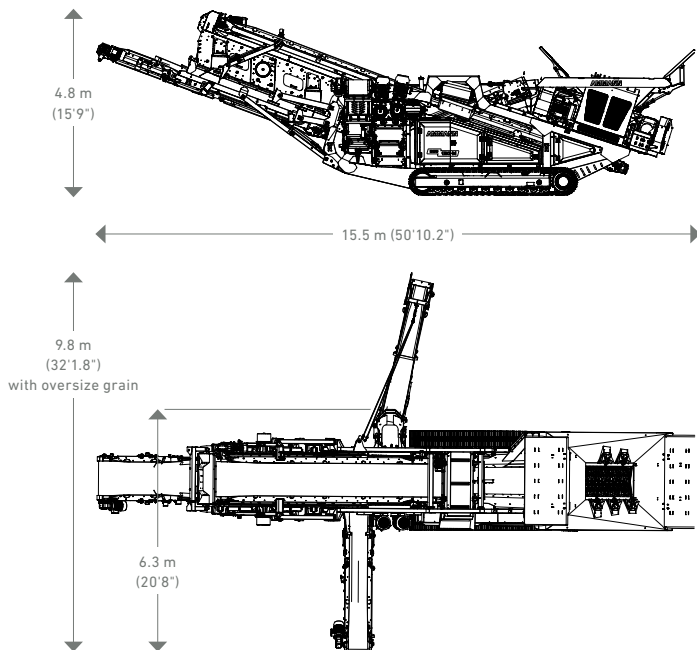

WIDTH	6.3 m (20'8")
WIDTH WITH OVERSIZE GRAIN	9.8 m (32'1.8")
LENGTH	15.5 m (50'10.2")
HEIGHT	4.8 m (15'9")

TRANSPORT CONDITIONS

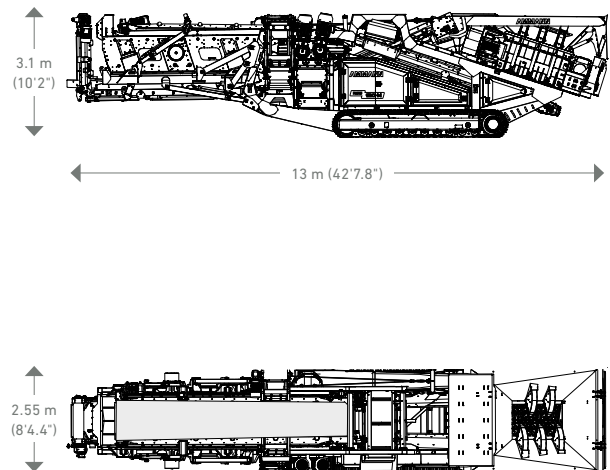

WIDTH	2.55 m (8'4.4")
LENGTH	13 m (42'7.8")
HEIGHT	3.1 m (10'2")

SPECIFICATIONS

GENERAL INFORMATION

MIN. PROCESSING PERFORMANCE WITH MILLED MATERIAL	120 tons/h (132 short tons/h)
MIN. PROCESSING PERFORMANCE WITH SLABS (1000 mm)	80 tons/h (88 short tons/h)
MAX. PERFORMANCE	180 tons/h (198 short tons/h)
NUMBER OF FINAL PRODUCTS	2 + oversize grain
WEIGHT	35 500 kg (77,162 lbs)

FEED HOPPER

SURFACE OF THE HOPPER	2.50 × 2.30 m (8'2.5" × 7'6.5")
HOPPER VOLUME	3 m ³ (3.92 yd ³)
HYDRAULIC FEED HOPPER EXTENSION EXTENSION VOLUME	3 m ³ (3.92 yd ³)

SCREEN

SCREEN AREA	4.25 × 1.3 m (13'11" × 4'3")
SCREEN CAPACITY	max. 190 t/h (210 short tons/h)
NUMBER OF SCREEN DECKS	2
ELECTRICAL POWER	8 kW

OVER BELT MAGNET

WIDTH CONVEYOR BELT	650 mm (2'1.6")
LENGTH CONVEYOR BELT	1660 mm (5'5.4")
POWER	420 Gauss to 200 mm (420 Gauss to 7.9")
ELECTRICAL POWER	1.5 kW

HYDRAULIC CRAWLER TRACKS

AXIS DISTANCE	3620 mm (11'10.5")
CHAIN WIDTH	400 mm (15.8")
GEAR	Transmittal
SPEED	0.2–0.8 km/h (0.12–0.5 mph)

STANDARD EQUIPMENT

- Radio remote control for all drives and tools
- Multifunction control for easy operation and troubleshooting

GENERATOR SET

ELECTRIC POWER DIESEL PACK, IVECO C87 256 KW, GENERATOR 400 KVA	
ENGINE TYPE	FPT Cursor 87 TE3F 256 KW 1500 rpm
EMISSION CLASS AND CATEGORY	Stage III A/ Tier 3 (Genset 1500 rpm)
DIESEL PARTICULATE FILTER DPF	optionally available
FUEL TANK CAPACITY	85 l (22 U.S. gal)
HYDRAULIC OIL TANK	220 l (58 U.S. gal)
DIESEL FUEL TANK	

CRUSHER TYPE "SHREDDER": FTR 1200

SHREDDER TYPE	FTR 1200
CRUSHER INLET	1200 × 900 mm (3'11.2" × 2'11.4")
NUMBER OF KNIVES	n° 24
WIDTH OF KNIVES	50 mm (1.9")
ELECTRICAL POWER	60 kW (30 + 30)
ROTATION SPEED	10 rpm
HYDRAULIC PUSHERS	5
PRIMARY CRUSHING GAP	hydraulically adjustable

SECONDARY SHREDDER

CRUSHER INLET	1200 × 700 mm (3'11.2" × 2'3.6")
SHREDDER PLATES	n° 32 (16 + 16)
TEETH HEIGHT	15 mm (0.6")
ELECTRICAL POWER	44 kW (22 + 22)
ROTATION SPEED	20 rpm

OPTIONAL EQUIPMENT

- Water spraying system for dust suppression
- Scales for fine and medium grain belt
- Pump for re-filling fuel tank
- Paint customized 2 colors
- Diesel particulate Filter DPF

For additional product information
and services please visit:
www.ammann-group.com

